

## 12" Turbine Pitless Parts Breakdown

ANY ORDER FOR REPAIR PARTS MUST BE ACCOMPANIED BY THE PITLESS UNIT SERIAL NUMBER AND ORDER NUMBER

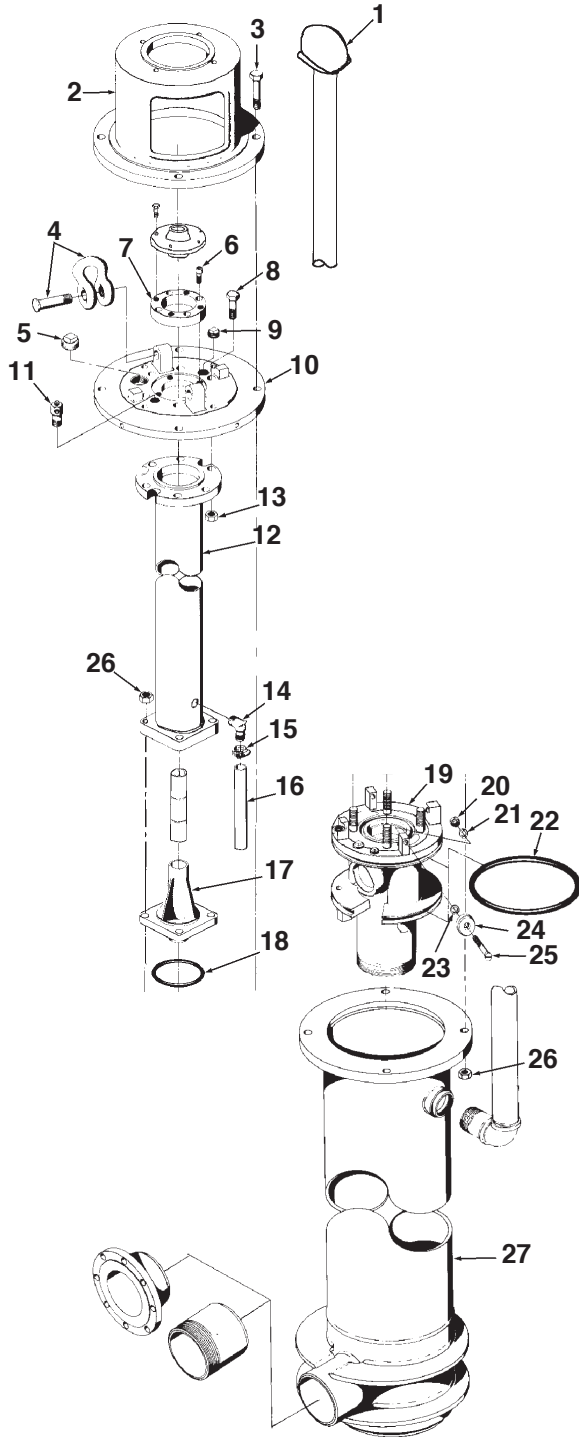

Key No.	Qty	Description	Ord. No.
1	1	Screen Well Vent 2 1/2" NPT	PS155
2	1	Motor Support Stand	UK400
3	4	Hex Head Cap Screw 3/4"-10NCx4" L.	UK470
4	2	Screw Pin Anchor Shackle-1 1/8" Bow Size	UK469
5	1	Pipe Plug 1 1/2x11 1/2" NPT	UG54
6	4	Hex Socket Cap Screw-1/2-13NCx3 1 1/2" L.	UK468
7	1	Upper Bearing Seal Housing (Machined to customer specifications)	UK564
8	6	Hex Head Cap Screw-7/8-9NCx3 1/2" L.	UK471
9	1	Pipe Plug, 1"-11 1/2"NPT	SW33
10	1	Motor Support Plate	UK550
11	1	Air Test Adapter	UK180
12	1	Lift-Out Pipe Assembly	UK157
13	10	Hex Nut, 7/8-11NC	UK188
14	1	Elbow, 3/4" IPx 3/4"-Plastic	UM149
15	1	Pipe Clamp - 3/4"	UM147
16	1	Drain Pipe	UM142
17	1	Bearing Seal Housing	UK183
18	1	Static Seal Ring	PS575A
19	1	Spool Assembly (Order by description & Unit Serial No.)	-----
20	4	Hex Nut, 3/8-16NC	UB17
21	4	Lockwasher	TX31
22	2	Static Seal Rings for spool	UK15
23	4	Washer	SW68
24	4	Washer	UL95
25	4	Machine Screw, 3/8-16NCx2 1/4" L	UM222
26	4	Hex Nut, 3/4-10NC	UM33
27	1	Discharge Body & Upper Case Assembly (Order by description & Unit Serial No.)	-----