



16" PITLESS BOOSTER UNIT

UNITS AVAILABLE BY QUOTATION ONLY
6" THROUGH 36" TANK SIZES

EXPLANATION OF PITLESS BOOSTER UNIT ORDERING NUMBERS

The diagram illustrates the meaning of the various letters and numerals used in Monitor Pitless Booster Unit ordering number. A typical order number and the pitless booster unit it stands for are shown.

Typical Order Number 6PS1618WBWX08F868FES

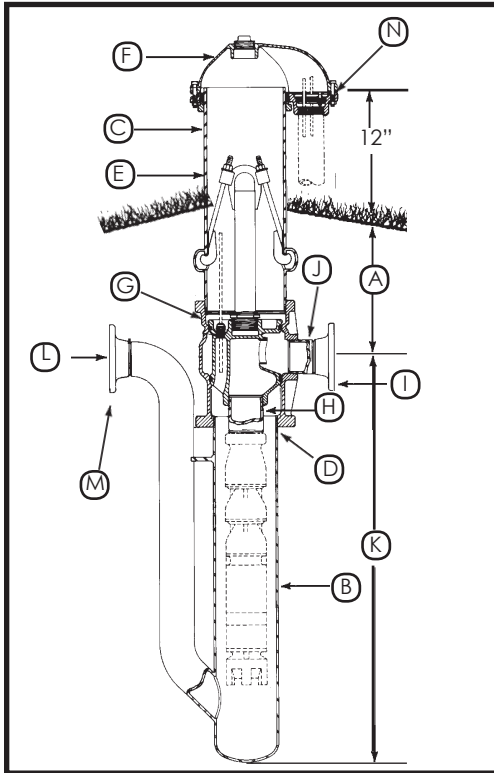

- 6** A. This first numeral in the order number indicates the bury depth, in feet, of the unit. Bury depth on all units is measured from the center of the discharge line to ground level. The top of the pitless case extends 12" above ground level as is required by many codes.
- PS** These letters indicate the type of pump the Pitless Booster Station is designed for. The unit shown is a PS for Submersible Pumps.
- 16** B. This numeral indicates the reservoir tank size. 16 is for an 16" I.D. diameter tank.
- 18** C. This numeral indicates the upper pitless case size, 18 is for a 18" diameter case.
- W** D. This letter indicates the attachment to the reservoir tank is a welded joint on 8" - 30".
- B** E. The presence of the letter "B" in the order number indicates the upper pitless case is black pipe.
- W** F. Indicates the unit has a watertight cap.
- X** G. Indicates spool passages are closed.
- 0** This numeral indicates the type of spool which the pitless unit has. In this case it is a spool that has no check valves.
- 8** H. Indicates the size of drop pipe in inches.
- F** I. Indicates the discharge connection is flanged.
- 8** J. Indicates the size of discharge pipe in inches.
- 6** K. Indicates the length of the reservoir tank in feet, and is measured from the center of the discharge line to the bottom of the unit.
- 8** L. Indicates the inlet connection diameter in inches.
- F** M. Indicates the inlet pipe connection is flanged.
- E** Indicates this is a standard unit.
- S** N. Sealed conduit connection. (Optional)

DESCRIPTION - ORDERING NUMBERS		
A	6	Bury Depth in Feet
	PS	Pitless Booster for Submersible Pump
B	16	Reservoir Tank Size - Ins.
C	18	Upper Case Size - Ins.
D	W (T)	Threaded Joint (W) Welded
E	B	Black Upper Case
F	W	Watertight Cap
G	X	Motor Cable Passages - Sealed
	0	Check Valves: 0
H	8	Size of Drop Pipe in Ins. (5", 6" or 8")
I	F	Welded
		Flange, ASA 150#
		Threaded NPT
		Mech. Joint w/trans. sleeve
		Discharge Connection (Select One)
J	8	Size of Discharge Pipe - Ins.
K	6	Length of Reservoir Tank - Feet
L	8	Inlet Pipe Size - Ins.
M	F	Welded
		Flange, ASA 150#
		Threaded NPT
		Mech. Joint w. trans. sleeve
		Inlet Pipe Connection (Select One)
	E	Standard Unit
N	S	Elec. Cable Seal(S)
		O.D. 3 Wire O.D. Ground Wire
		Special Provision (X)