

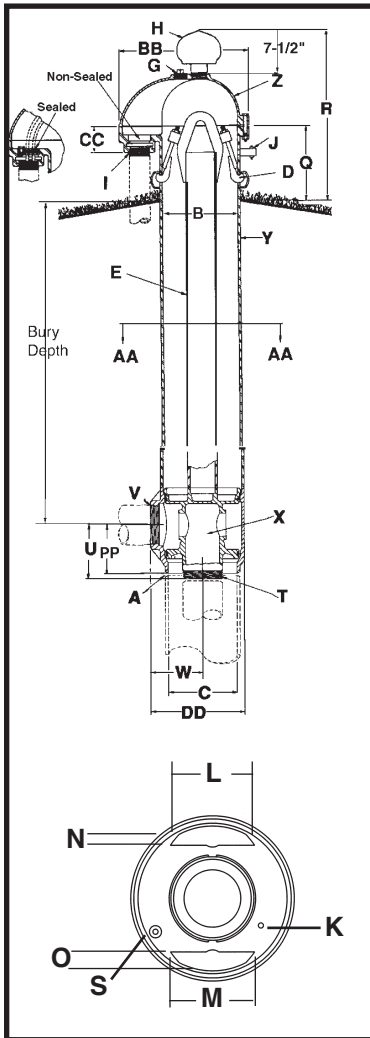

16" O.D. STANDARD INDUSTRIAL SPECIFICATIONS



- A Pitless Unit to Well Casing Connection:Chamfered for butt weld
- B Pitless Unit with black upper case:17-1/4" I.D., 18" O.D.
- C Discharge body minimum I.D.15-1/4"
- D Hold-down Mechanism:Locks spool in place and prevents lifting and turning during pump start-up. Four adjustable hooks on lift-out pipe hook into side of pitless case.
- E Lift-out pipe with lifting bail: 5" weld assembly designed for a 103,000 lb. load
- G Tap Size:2" NPT
- H Well vent:Screws into a 2-1/2" NPT tap
- I Conduit tappings: 2" & 1" NPT std. Also available with single 2", 3" or 4" NPT
- J Depth tester block tappings: 1/4" NPT
- K Pressure zone tappings: (1) 3/8" NPT
- L **MOTOR CABLE PASSAGES THROUGH SPOOL (SECTION AA-AA)**
Will clear rigid rod parallel to casing 1.93"
- M 4-9/16"
- N Some restrictions apply..... 1-1/8"
- O 2"
- PP Dimension from center of discharge outlet to bottom of weld ring:..... 13-11/16"
- Q Distance from ground level to top of the pitless case: 12"
- R Distance from ground level to top of the screened well vent:.....28-1/4"
- S Water sampler tapping (optional):.....3/4" NPT
- T **SPOOL TO DROP PIPE CONNECTION:**8" male NPT tapping Spool designed for 103,000 lb. load
- U Dimension from center of discharge outlet to bottom of spool: 12-5/16"
- V Discharge connection tapping size:8" NPT
- W Dimension from center of well casing to the end of discharge outlet: 11"
- X **SPOOL ASSEMBLY**
- Y Pitless case wall thickness:375"
- Z **SEAL CAP:** Watertight cap bolts to a gasketed surface securing around the pitless casing and comes installed with 2-1/2" screened well vent.
- BB Overall length of seal Cap:.....25-3/8"
- CC6-1/4"
- DD20-1/8"

SPECIFICATIONS ARE SUBJECT TO CHANGE WITHOUT NOTICE

*For Flowing Well spool concept, see Booster Station section.

*Optional flange, weld or mechanical joint available upon request.

Note: Pitless units conform to the Recommended Standards for Water works, Great Lakes Upper Mississippi River Board of State Public Health & Environmental Managers and Water Systems Council PAS-97 standards.

COMPONENT MATERIALS

- Well Vent:** cast iron, green enamel finish.
- Cap:** cast iron, green enamel finish.
- Hold-Down & Lift-Out Mechanism:** Black Steel
- Hold-Down Pipe:** Steel, corrosion resistant coating.
- Pitless Case:** Steel, corrosion resistant coating.
- Spool:** Lead-Free Galvanized ductile iron.
- Discharge Body:** Lead-Free Galvanized ductile iron.
- Electrical Conduit Cable Seal:** Neoprene
- Maximum rated discharge pressure - 300 PSI**

BB-3-16(05-08)