

6.6" I.D. STANDARD INDUSTRIAL SPECIFICATIONS

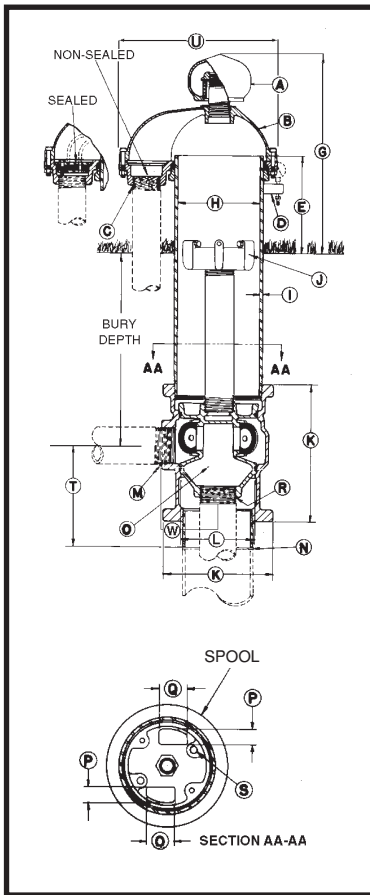

*For Flowing Well spool concept see Booster Station section.

*Optional flange, weld or mechanical joint available upon request.

Note: Pitless units conform to the Recommended Standards for Water works, Great Lakes Upper Mississippi River Board of State Public Health & Environmental Managers and Water Systems Council PAS-97 (04) Standards.

- A Screened Well Vent tap size: 1-1/2" NPT
- B Seal Cap: *The Watertight cap bolts to a compression seal ring securing around the pitless case and comes with the screened well vent installed.*
- C Conduit Tapping size: 1-1/2" NPT
Watertight conduit seals for most common cable sizes are available for watertight cap.
- D Depth Tester Tapping: 1/4" NPT
- E Distance from ground level to top of Pitless Case: 12"
- G Distance from ground level to top of Screened Well Vent: 19-1/2"
- H Pitless Case I.D. size: 7"
- I Pitless Case wall thickness:300"
- J "Hold-Down" - "Lift-Out" Mechanism
Three set screws in a spider atop the "Hold-Down" - "Lift-Out" pipe brace against the interior of the pitless casing, locking the spool in place.
Hold-Down, Lift-Out pipe size (Schedule 80): 2" NPT
Designed "Lift-Out" Mechanism load: 15,000 lbs.
- DISCHARGE BODY - THREADED**
- K Discharge Body outside diameter: 9-11/16"
- K Discharge Body length: 11-1/4"
- L Pitless Unit minimum inside diameter: 6-3/8"
- M Discharge Connection Tapping size: 3" NPT
- N Pitless Unit to well casing connection I.D.: 6.6" Weld
- O SPOOL ASSEMBLY**
Spool Design Load: 15,000 lbs.
- P MOTOR CABLE PASSAGES THROUGH SPOOL** 13/16"
- Q 1-3/4"
- R Spool to Drop Pipe Connection: 3" NPT
- S Pressure zone tapping: 3/8" NPT: (2) available
- T Dimension from center of discharge outlet to bottom of weld nipple: 9-3/8"
- U Overall length of seal cap: 12-7/8"
- V Dimension from center of discharge to bottom of discharge body: 7-3/4"
- W Dimension from center of well casing to end of discharge outlet: 5-25/32"

Specifications are Subject to Change Without Notice.

COMPONENT MATERIALS

Well Vent - cast iron, green enamel finish.
 Cap & Conduit Box - cast iron, green enamel finish.
 Hold-Down Spider - cast iron, green enamel finish.
 Hold-Down Pipe, 2" - steel Sch. 80, black.
 Pitless Case - steel, black.
 Spool - cast iron, lead-free galvanized.
 Discharge Body - cast iron, lead-free galvanized.
 Check Valve Body & Arms - brass.
 Check Valve Seat - Brass.
 Check Valve Spring - Monel.
 Compression Seal Ring & Check Valve Facing - Neoprene.
 Electrical Conduit Cable Seal - Neoprene.
 Maximum Rated Discharge Pressure - 300PSI

BB-1-6.6(05-08)