

18" Custom Pitless Parts Breakdown

ANY ORDER FOR REPAIR PARTS MUST BE ACCOMPANIED BY THE PITLESS UNIT SERIAL NUMBER AND ORDER NUMBER

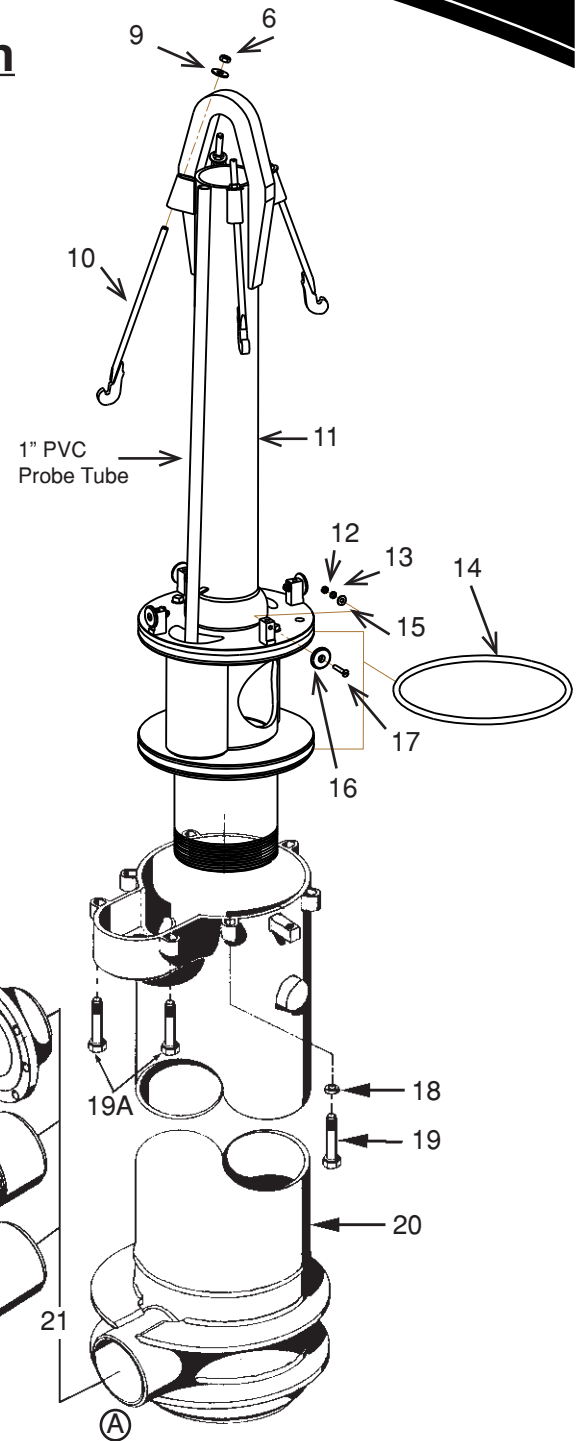
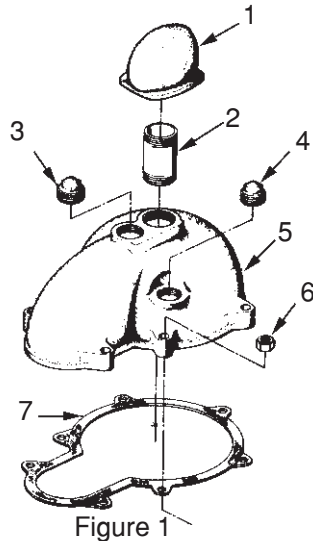

Key No.	Quantity	Description	Ord. No
FIGURE 1			
1	1	Protected Screen Well Vent 2 1/2" NPT	PS155
2	1	Pipe Nipple 2 1/2" NPT x 6" L.	PS365
3	1	Plug Plug 2" NPT	UJ50
4	1	Pipe Plug 1 1/2" NPT	UG54
5	1	Seal Cap	UN1
6	9	Hex Nut 5/8-11NC	PC286S
7	1	Gasket	UN72
FIGURE 2			
9	4	Washer	PC417
10	4	Hold-Down Hook	UN7
11	1	*Spool & Lift-Out Assembly (Serial No. Required)	-----
12	4	Hex Nut 3/8-16NC	UB17
13	4	Lockwasher	TX31
14	2	O-Ring	UN15
15	4	Washer	SW68
16	4	Washer	UL95
17	4	Machine Screw, 3/8-16NC x 2 1/4" L.	UM222
18	7	Washer	UN81
19	5	Hex Head cap screw, 5/8-11NC x 5" L.	UN73S
19A	2	Lock Bolt, 5/8-11NC x 4 3/4" L.	LK4S
20	1	Discharge Body & Upper Casing Assembly----- (Serial No. Required)	-----
21	---	(4) different discharge connections are available, (A) Welded, (B) Flanged, (C) Threaded or (D) Mechanical Joint with or without Transition Sleeve	

*Flowing Well Spools Available upon request