

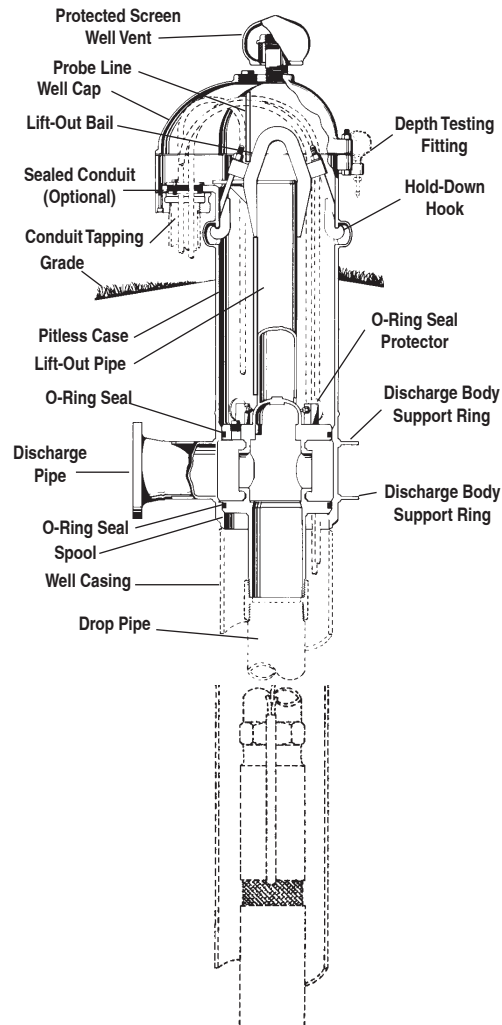

CUSTOM INDUSTRIAL PITLESS UNITS



The Monitor PS Custom Industrial Pitless Unit for submersible pumps forms a watertight extension of the well casing. The Pitless Unit connection to the well casing starts below the frost line. From the connection point, it extends upward finishing 12 or more inches above grade. The casing extension above grade is then completed with a watertight cap.

Monitor units conform to the Recommended Standards for Water Works, Great Lakes Upper Mississippi River Board of State Public Health & Environmental Managers, Water Systems Council and PAS-97 (04) Standards.